

CHANNEL SECT.700 CM 500x70xH.63

IRRIGATION CHANNEL

Water has long been considered one of the most valuable resources on our planet.

The importance of preserving this natural element has led us in the early eighties to market prefabricated channels that would bring numerous benefits to those who had to use this resource: we are talking about the world of agriculture. For 30 years, this prefabricated product has been appreciated in the sector due to the positive benefits it provides:

- Elimination of water losses due to natural soil absorption or infiltration due to damage caused by rodents.
- Near elimination of routine weed cleaning from the channel bed.
- Simplification of irrigation interventions.
- Low cost, simplicity and speed of installation.
- Perfectly smooth inner surface that provides greater and better water flow.
- Low environmental impact.

The channels are widely used, as well as in agriculture, also in road systems as a channel for collecting waste water at the roadside. The design is based on the assumption that they should be placed alongside transit zones for vehicles and people, therefore meeting certainly different safety criteria. The prefabricated channels are placed on plinths with dimensions chosen according to the nature of the land and in relation to the type of channel. The spigot joint enables connection between one element and another and the gasket ensures the water tight sealing of the product.



FATTORI
SISTEMI E STRUTTURE IN CEMENTO ARMATO

Via F. Cavallotti, 298 - 25018 Montichiari (Bs-Italy) - Tel. +39 030.963291 - Fax +39 030.9964333
www.gffattori.com - info@gffattori.it

TECHNICAL SPECIFICATIONS

SPIGOT SECTION VIEW

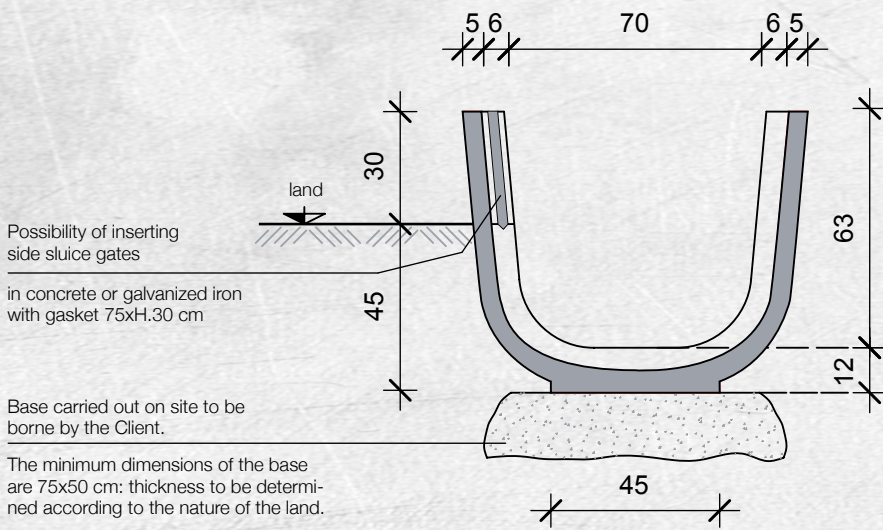

CHANNEL PLAN VIEW

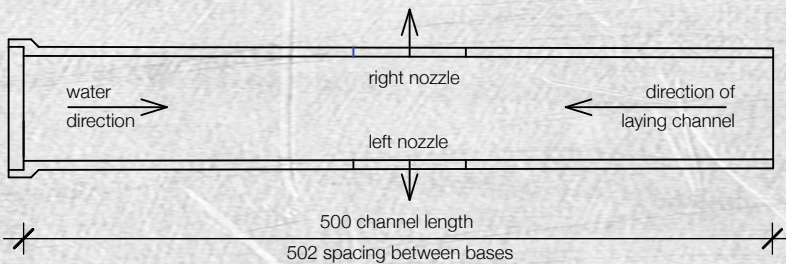

CHANNEL LOADING

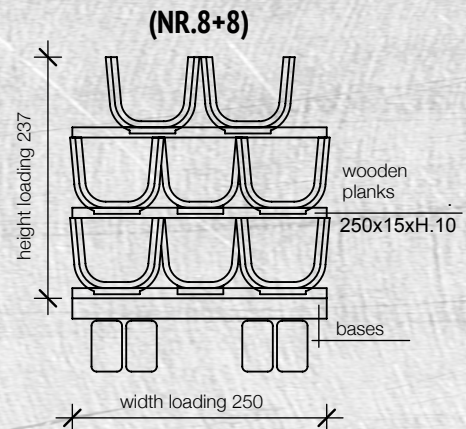

JOINT CLOSE-UP

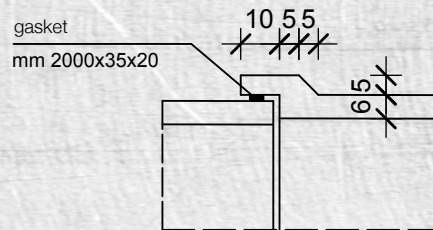

TECHNICAL SPECIFICATIONS	
WEIGHT OF AN ELEMENT	kg 1450
INTERNAL SURFACE FINISH	VIBRATED CONCRETE
2nd COEFFICIENT BAZIN'S FORMULA	C=0,16

WATER SPECIFICATIONS						
CLEARANCE (CHANNEL WATER LEVEL) cm.	0 (cm 63)	4 (cm 59)	8 (cm 55)	20 (cm 43)	40 (cm 23)	
LIQUID AREA mq.	0,39	0,36	0,33	0,25	0,13	
WATER LINE m.	1,71	1,63	1,55	1,31	0,91	
FLOW litres/sec. WATER SPEED m/sec.	SLOPE i=0,0002	171 0,44	157 0,43	142 0,42	101 0,40	40 0,32
	SLOPE i=0,0005	271 0,69	248 0,68	225 0,67	159 0,63	63 0,50
	SLOPE i=0,001	383 0,98	350 0,97	318 0,95	225 0,89	89 0,71
	SLOPE i=0,002	542 1,39	495 1,37	450 1,34	319 1,25	126 1,01