

GRID SUPPORTING TANK AND SIDE WALL

PREFABRICATED PRODUCTS FOR EXTERIOR BOXES

These are prefabricated elements for the installation of exterior boxes.

The grid supporting tank is available in different heights and widths. They are modules with a useful length of 242 cm and their installation requires the production of support strips at the joints, and the application of a gasket (supplied by Fattori srl) that guarantees a perfect sealing.

The side wall is anchored to the side of the tank with suitable Z-shaped brackets and anchor plugs made of galvanized steel. An additional fixing device is applied centrally between one element and the other to guarantee the perfect stability of the whole structure. The unit is completed with the sealing, using silicone material, resistant to acids, between the tank and the side wall and finally the laying of the grid and the partitions for the subdivision in boxes.

These structures enable the rapid production of exterior boxes in a short time and at low cost.

The side wall is also used as a buffer panel in pigsties made with galvanized iron structures and ensuring adequate external insulation.



FATTORI
SISTEMI E STRUTTURE IN CEMENTO ARMATO

Via F. Cavallotti, 298 - 25018 Montichiari (Bs-Italy) - Tel. +39 030.963291 - Fax +39 030.9964333
www.gffattori.com - info@gffattori.it

TECHNICAL SPECIFICATIONS

TANK-SIDE WALL PLAN VIEW

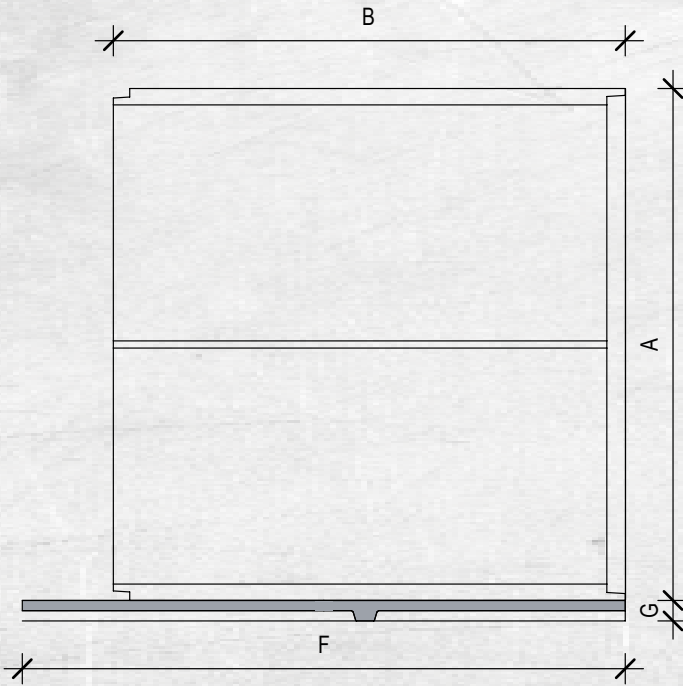

TANK-GRID-SIDE WALL AND PERFORATED PARTITION WITH FOOT SECTION VIEW

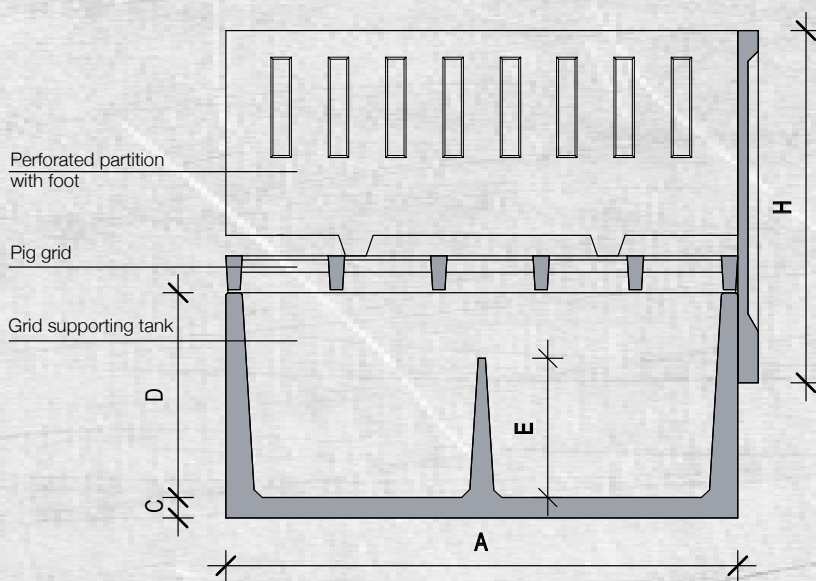

TECHNICAL CHARACTERISTICS OF THE ELEMENT	
VARIABLE LIVE LOAD: 500 Kg/mq in addition to its own weight	
CONCRETE: R'ck formwork ≥ 20 N/mmq R'ck in 28 day ≥ 40 N/mmq	
STEEL B450C checked: fyk ≥ 450 N/mmq ftk ≥ 540 N/mmq	
WELDMESH: Steel B450A	
EXPOSURE CLASS	XC3-XA2
bar cover	2,5cm
bar free interspace	≥ 2 cm $\geq \emptyset$ max
REI	30
TOLLERANCE	
length	$\pm 1,0$ cm
height	$\pm 0,5$ cm
width	$\pm 1,0$ cm
mild reinforcement	$\pm 1,0$ cm

ITEM CODE	Description	A cm	B cm	C cm	D cm	E cm	Weight Kg/cad
VASD15070	Tank without partition H.70	150	242	10	70	//	1900
VASD150100	Tank without partition H.100	150	242	10	100	//	2180
VASD20070	Tank without partition H.70	200	242	10	70	//	2160
VACD20070	Tank with partition H.70	200	242	10	70	68	2360
VASD200100	Tank without partition H.100	200	242	10	100	//	2460
VACD200100	Tank with partition H.100	200	242	10	100	68	2660
VASD25070	Tank without partition H.70	250	242	10	70	//	2560
VACD25070	Tank with partition H.70	250	242	10	70	68	2760
VASD250100	Tank without partition H.100	250	242	10	100	//	2880
VACD250100	Tank with partition H.100	250	242	10	100	68	3080

ITEM CODE	F cm	G cm	H cm	Weight Kg/cad
MURO500172	500	10	172	1340

ITEM CODE	Length cm	Width cm	Height cm	Weight Kg/ml
DIVPALES2	max 272	6	110	120

The table shows the standard sizes; we can also produce non-standard sizes upon prior arrangements with our offices.

The sizes shown are indicative, **FATTORI** reserves the right to make any changes at any time without prior notice.